



47<sup>TH</sup> TURBOMACHINERY & 34<sup>TH</sup> PUMP SYMPOSIA  
HOUSTON, TEXAS | SEPTEMBER 17-20, 2018  
GEORGE R. BROWN CONVENTION CENTER

## THE SYNCHRONOUS ROTOR INSTABILITY PHENOMENON - MORTON EFFECT

**Frits de Jongh**  
Engineering Manager  
EthosEnergy  
Hengelo, the Netherlands



*Frits de Jongh is Engineering Manager for EthosEnergy B.V., in Hengelo, the Netherlands. He has more than 35 years of experience with turbomachinery comprising compressor and steam turbine design work, performance testing of rotating machinery, vibration analyses, and rotordynamic research. Following his engineering and management career at Delaval-Stork, Siemens Industrial Turbomachinery and TurboCare, he joined the EthosEnergy organization in 2014 and is currently responsible for compressor and industrial steam turbine engineering. Mr. de Jongh received a B.Sc. degree (Mechanical Engineering, 1980) from the Dordrecht Institute of Technology. He has authored and coauthored several technical papers on turbomachinery. Mr. de Jongh is a Fellow of the Institution of Mechanical Engineers (IMEchE).*

### ABSTRACT

This paper gives an overview on the “Morton Effect” and explains how synchronous rotor instability, due to nonuniform heating of bearing journals, can occur in high-speed turbomachinery. The paper was presented before as a tutorial paper (de Jongh, 2008). Now, 10 years later, the paper has been updated with the latest published information on this subject. Theoretical investigations by Keogh and Morton (1993, 1994) indicate that rotors supported by fluid-film bearings inherently exhibit a nonuniform temperature distribution along the bearing journal circumference. This thermal effect results in rotor bending, which can, in combination with an overhung mass such as couplings and overhung impellers, significantly increase rotor unbalance and thus synchronous rotor vibration. Under certain conditions, it can lead to synchronous rotor instability. Experimental studies have subsequently been performed verifying the existence of this rotordynamic phenomenon (de Jongh and Morton, 1994) that is more commonly known as the Morton Effect. In this paper, the phenomenon is explained and an overview is given of the existing literature on this subject. Since 2008, a significant amount of research has been carried out on this subject and new papers have been published especially on various methods to predict the Morton Effect from a theoretical point of view. A number of other papers show case studies with pragmatic solutions for unstable synchronous rotor behavior. These are discussed in more detail.

### INTRODUCTION

Synchronous rotor instability, due to bearing journal differential heating, is still a lesser known rotordynamic phenomenon. One reason may be that the phenomenon is not recognized when analyzing vibration data of turbomachinery. In the event that bearing journal differential heating is considered as a possibility, it will be difficult, if not impossible, to measure bearing journal temperatures on the shaft to prove this is the root cause of rotor vibrations. The effect however can very well be recognized if one is familiar with the phenomenon and its characteristics. It is the objective of this paper to give an elementary description of the phenomenon, provide information on how it can be recognized, and finally, how preventive and/or corrective actions can be taken. A typical case study on a 30,000 hp gas boost compressor is given as an example. The high power requirement of this compressor required a large shaft end and coupling that increased the sensitivity of the rotor to synchronous rotor instability. The rotordynamic effect of shaft-labyrinth rubbing, and consequential thermal shaft bending, is referred to as the “Newkirk Effect” (Newkirk, 1926) and clearly explained by Dimarogonas (1973). The effect is also referred to as “spiral vibrations,” due to its spiraling vibration behavior at constant rotor speed when shown in a Nyquist graph or polar plot. Kellenberger (1979) described that spiral vibrations can also be caused by stationary elements other than labyrinths, such as seal rings.

He investigated synchronous rotor instability due to generator hydrogen seal rings under various combinations of support conditions. The mechanism for the production of a hot spot on the shaft was friction as in a rub. The Morton Effect however, is concerned with a thermohydrodynamic source of shaft heating.

Schmied was the first who presumed in one of his technical papers that this phenomenon could exist in fluid-film bearings (Schmied, 1987). Although this was the first publication in open literature, the phenomenon was investigated before (Morton, 1975; Hesseborn, 1978).

Keogh and Morton (1993) indicated that thermal shaft bending could be developed in a fluid-film bearing because of nonuniform viscous shearing in the oil-film. Under certain circumstances, this can create similar “spiral vibrations” as in the Newkirk Effect.

De Jongh and Morton (1994) described a case study on a natural gas compressor for an offshore gas lift application. For this compressor the synchronous vibration problem on the test stand was resolved by reducing the weight of the couplings. However, the true nature of the vibration mechanism was not fully understood at the time of shipment. Further research was carried out on a scaled test rotor of this specific compressor. By measuring the temperature distribution around a rotating bearing journal, the vibration behavior of this compressor rotor was explained. Being aware of the investigations and the interesting results of this rotordynamic research, John Kocur Jr. (in those days at Delaval Inc.) was the first one who described this phenomenon as the “Morton Effect.”

## HISTORY

Various conversations between the author and Paul Morton led the author to presume that in the late 1970s, this specific phenomenon with fluid-film bearings and seal rings was known by two different turbogenerator manufacturers in Europe, namely:

- General Electric Company Ltd. in the United Kingdom (GEC)
- Stal-Laval Turbin AB in Sweden (ASEA)

Specific experimental investigations on this subject were performed by both companies. To the best of the author’s knowledge, the earliest of these investigations date from the year 1975 (Morton, 1994). Morton explained to the author that prior to 1975, when he formulated the basic theory, several empirical approaches were used to cure the rotordynamic problems. A reduction on overhang mass proved beneficial and another approach was simply to increase the bearing clearance, so that cooling oil flow was increased. In a number of cases, he indicated it was sufficient to wait until the troublesome machine was rigidly coupled to another machine, thereby reducing the overhang sensitivity. In 1975, Morton performed experiments in a rig on a typical 28 inches (711 mm) diameter shaft running at 1800 rpm. In order to measure the temperature profile along the circumference of the rotating shaft, the shaft was instrumented with 12 thermocouples, equally spaced along the shaft circumference. The orbit size during these tests could be altered by an eccentric device used on the shaft. It was found that significant differential temperatures were measured across the shaft, even for shaft orbits of only a few percent of the radial clearance (Morton, 1994, 2008). A linear relationship between differential temperature and orbit size was identified during these experiments. In 1976, Morton observed spiral vibrations, due to this effect, on particular designs of industrial gas turbines (Keogh and Morton, 1993).

In 1978, the phenomenon was investigated by Hesseborn who performed experiments on a bearing test rig (Hesseborn, 1978). Larsson analyzed the results of this report and concluded that an almost linear relation exists between bearing journal vibration and differential temperature across the journal (Larsson, 1999a).

According to the Author’s experience, in the past quite often rotor vibration problems related to large overhung weights were characterized with the term ‘overhang critical.’ Although that may have been the case, bearing journal differential heating could have played a major role in these vibration problems. Usually a reduction in rotor overhang weight solved the problem of these machines.

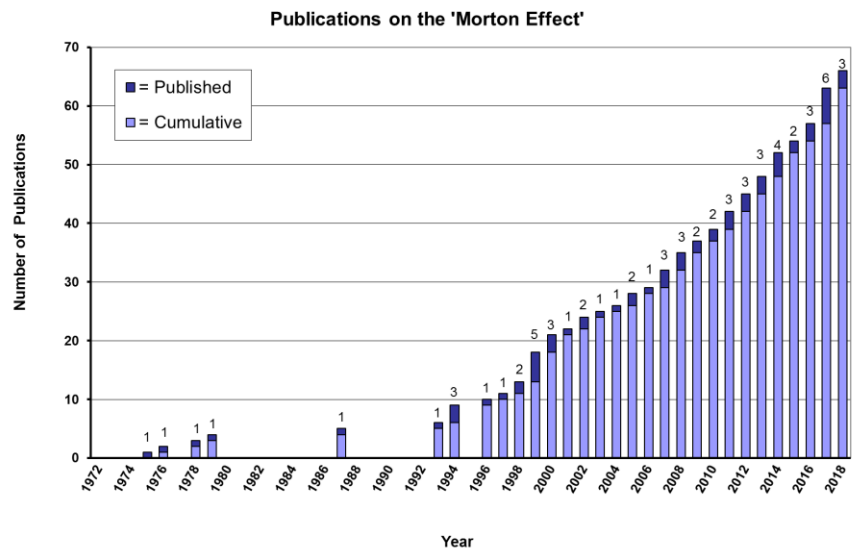

Figure 1. Publications on the Morton Effect (Years 1975, 1976, and 1978 are Internal Reports)

Dr. Dara Childs indicates in his paper on rotordynamic developments at the end of the 20<sup>th</sup> century that Morton Effect instabilities were ‘like a widely-spread but undiagnosed disease.’(Childs, 2015).

From 1993 more technical papers on this subject were published including a number of papers that described the first case studies for which the Morton Effect was recognized as the root cause (Faulkner, et al., 1997; Berot and Dourlens, 1999; Marscher and McGinley, 2004). Given the upswing in literature published over the last 25 years, it appears that the phenomenon is more studied and also recognized more often as the root cause of unstable rotor vibrations. Figure 1 gives an overview of the number of technical papers written on this subject over the years. The overview also includes a paper describing the experimental pioneering phase of this phenomenon in 1975 (Morton, 2008).

## DESCRIPTION OF THE “MORTON EFFECT”

This section gives an elementary description of nonuniform bearing journal heating, which is the root cause of synchronous rotor instability. This type of rotor instability is caused by a temperature effect that, in practice, is present in all fluid-film bearings. The nature of the instability is synchronous with the rotor speed. Authors of traditional bearing literature generally assume that a rotating bearing journal has a uniform temperature distribution on the journal circumference. This assumption is not valid when a journal is orbiting in its bearing with a whirl frequency synchronous to the rotor speed. In fact, every journal will, due to residual unbalance in the rotor, execute a small synchronous orbit. A journal orbiting synchronously in a fluid-film bearing produces a temperature difference across its diameter. Figure 2 shows a bearing journal rotating at constant speed and executing a forward circular orbit. One specific point on the journal will always be located at the outside of the orbit, referred to as the “high spot.” At the high spot the time averaged distance from the shaft to the bearing wall ( $h_2$ ) is always smaller than the opposite spot on the shaft ( $h_1$ ). Since the friction losses are proportional to the velocity gradient in the oil-film, consequentially the heat input to the shaft, due to these friction losses, will not be uniform along the journal circumference. This differential heat input results in a nonuniform circumferential shaft temperature profile and ultimately in a thermal bend. The larger the size of the orbit, the higher the differential temperature will be.

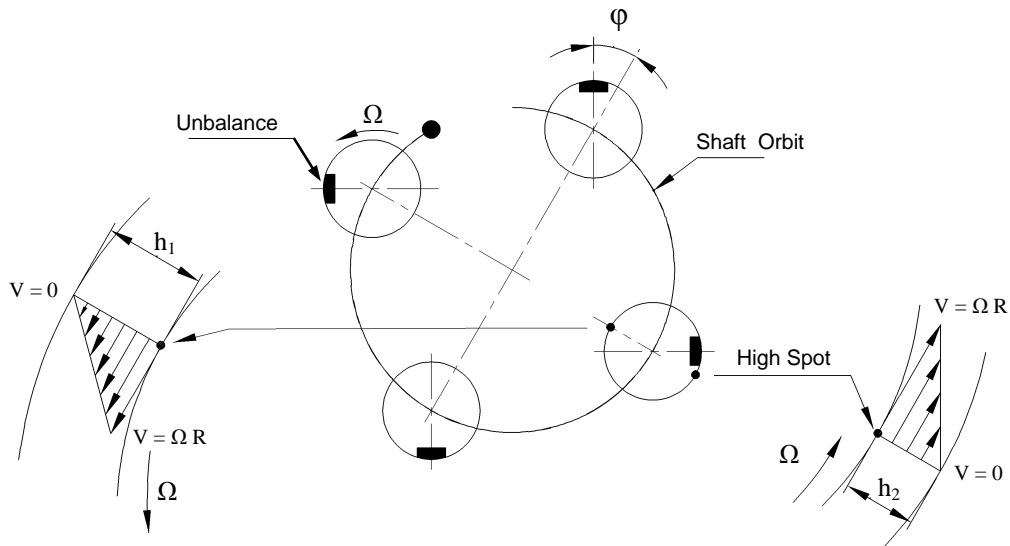

Figure 2. Differential Heating at Bearing Journal for Synchronous Forward Rotor Whirl

Since oil is convected counter to the journal rotation relative to the journal axes, the journal hot spot must lag the position of thinnest oil film (Figure 3). Measurements confirmed this phase lag between the point of thinnest oil film (high spot) and the hot spot on the journal circumference, giving evidence that the phenomenon was due to thermo-hydrodynamic action rather than solid friction such as rubbing (de Jongh and Morton, 1994). Figure 2 shows a forward circular orbit. The same principle applies to a backward orbit when the journal is positioned eccentric in the bearing, although the heat input will be smaller in this case. Since a linear system is assumed, the forward and backward thermal effects can be superimposed for an elliptical orbit. Figure 4 shows the thermal instability principle for a rotor with an overhung mass. For simplicity the overhung mass  $M_c$  is concentrated at the rotor end, at a length  $l$  from the bearing. If one assumes a very small synchronous orbit vector  $\epsilon$  at the bearing location and (due to the nonuniform heating) a small thermal bend  $\theta$ , an unbalance  $U = M_c l \sin(\theta)$  will result at the overhung end. This unbalance vector produces a new orbit vector at the bearing location altering the original orbit with the influence of the added unbalance. If the resulting orbit is smaller, the process will decay, but if the resulting orbit is larger, this process will continuously grow. In that case the system is unstable and the synchronous vibrations increase. Figure 5 shows the instability scheme, with a small initial thermal bend  $\theta_i$ .

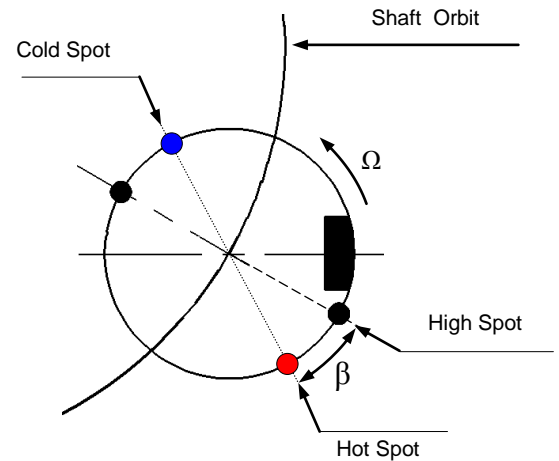

Figure 3. Journal Cross-Section Showing Phase Lag  $\beta$  between High Spot and Hot spot

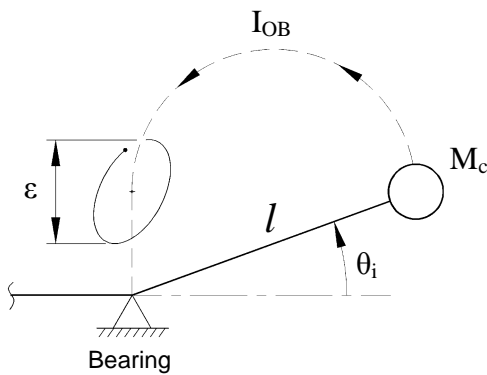

Figure 4. Thermal Rotor Bend at Bearing

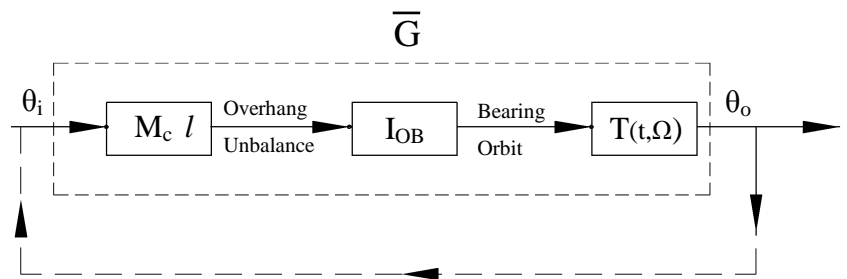

Figure 5. Scheme of Synchronous Instability Phenomenon

Already in the 1970s a few researchers carried out experimental investigations to examine the phenomenon. However, it appeared that most measurement results were recorded in internal company reports only (Morton, 1975; Hesseborn, 1978). Over the years more experiments on journal differential heating have been performed (de Jongh and Morton, 1994; Bradley, 2012; Panara et al., 2015; Tong and Palazzolo, 2018). The objective was obvious, obtaining temperature data for inclusion into calculation tools to prevent rotor instability during the design phase.

APPENDIX A gives an experimental verification of bearing journal differential heating as published by De Jongh and Van der Hoeven (1998).

## VIBRATION DIAGNOSIS

Certain rotor configurations are more susceptible to the Morton Effect. These are rotors with at least one free end supporting a relatively large overhung mass, i.e., flexible coupling, impeller, or expander wheel. Obviously, the rotor must be supported by fluid-film bearings.

Several case studies have been published on the Morton Effect. These publications have indicated how the phenomenon was detected from machinery vibration signal analysis. For vibration analysts it will be helpful to extract a few general rules to aide in the recognition of this specific rotordynamic problem.

1. The vibration signals are mainly synchronous with running speed (1x) and the effect looks very similar to a light rub between the rotor and a stationary part such as a labyrinth (Phuttipongsit, 2007). This makes it sometimes difficult to distinguish the effect from a rub as indicated by Newkirk. It means that in both cases, the Nyquist or polar plot will show spiral vibrations at constant rotor speed due to a moving hot spot and consequent thermal shaft bending. Although one of the differences between a light rub and the Morton Effect is that in the latter case a phase lag exists between the high spot and the hot spot on the journal circumference, in practice this usually cannot be verified.

Another difference between Newkirk's rub and the thermohydrodynamic phenomenon of Morton is that in the latter case the instability has an upper limit and indeed could occur over more than one speed range. Experiments have been executed in which a rotor was run through a thermal instability zone and stabilized at higher shaft speeds (de Jongh and Morton, 1994).

Some investigators have indicated that they removed all the labyrinth seals and/or floating seal rings from the machine in order to be sure that the spiral vibrations were not caused by these components. However, this is an extreme step and not always practical.

2. Since the Morton Effect is a thermal phenomenon, it can best be verified from a Bode plot by observing the synchronous vibration (1x) and corresponding phase during a machine run up and coast down. If during a run up thermal shaft bending occurs at a certain rotor speed, the thermal unbalance will result in an increase of synchronous rotor vibrations. When performing a quick reversal of speed, this will result in a hysteresis loop because of the time constants associated with a thermal phenomenon. It can be seen in Figure 6 that during reducing the rotor speed, the vibration level is much higher than during the run up. By holding the speed constant at a lower speed, the vibration level and phase return to the original run up values.

3. Another argument for nonuniform heating at the journal is that the behavior of spiral vibrations can be influenced by changing the oil flow rate and/or oil supply temperature. The effective oil viscosity in the bearing is a function of both oil inlet temperature and flow rate. Changes to the viscosity will influence the amount of heat generation in the oil film. It should be noted however, that bearing properties like stiffness and damping, which also influence the instability phenomenon, are related to the viscosity as well.

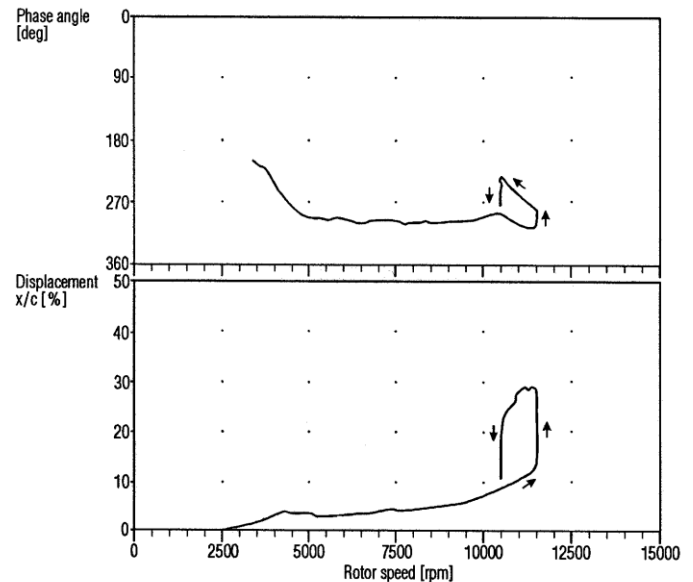

Figure 6. Bode Plot (1x) with Typical Hysteresis Loop (de Jongh and Morton, 1994)

It is worthwhile to note that it is possible to arrive at unstable running speeds where the phase change is in the direction of shaft rotation, against the direction of rotation or even without a phase change at all.

## TECHNICAL PUBLICATIONS

As mentioned before the number of technical publications on this subject has significantly increased over the years. Publications can be divided into pure theoretical papers describing the phenomenon from a mathematical point of view (Keogh and Morton, 1993, 1994; Larsson, 1999a, 1999b; Suh and Palazzolo, 2014; Tong and Palazzolo, 2016) and more practical papers describing case studies on synchronous rotordynamic vibration problems including methods and calculation tools to prevent these problems (Faulkner, et al., 1997a, 1997b; Berot and Dourlens, 1999; Kocur and de Jongh, 2000; Kirk, 2000; Marsher and McGinley, 2006; Schmied and Pozivil, 2008; Lorenz and Murphy, 2011). All case studies have in common that subjected rotors are supported by fluid-film bearings with relatively large overhung moments from impellers, expander wheels, or couplings. Figure 7 shows an overview of the different rotor types described in these investigations and case studies. Guo and Kirk (2011) published a paper in which they investigated the influence of the Morton Effect on a rotor with a single disk at mid-span and concluded that also for such a configuration rotor vibrations are influenced and may even result in rotor instability.

No.	Rotor Configuration		Case Study
1		Single Overhung Wheel	Berot et al., (1999), Kocur et al., (2000) de Jongh et. al., (1998)
2		Double Overhung Wheels	Faulkner et al., (1997b), Schmied et al., (2008)
3		2 Overhung Couplings (drive-through)	de Jongh et al., (1994)
4		1 Overhung Coupling	Kocur et al., (2000)
5		Integrally Geared, 1 Overhung Wheel	Carrick, (1999)
6		Integrally Geared, 2 Overhung Wheels	Marsher et. al., (2006),
7		Mid-span Rotor, 1 Disk	Guo et al., (2011)

Figure 7. Rotor Configurations from Various Case Studies and Investigations

Faulkner, et al. (1997a, 1997b), describe a case history of a radial inflow overhung turbine of a turbocharger, exhibiting synchronous rotor instability after a machine upgrade. The original design was changed in order to increase the capacity and efficiency of the turbocharger, resulting in a turbine wheel mass increase of around 20 percent. Changing the bearing geometry by creating a central undercut in the loaded bearing surface solved the vibration problem.

Carrick (1999) observed severely damaged impellers on integrally geared compressors and suggested that thermal shaft bending at the tilting pad bearings could very well have caused these failures.

Corcoran, et al. (1997), describe an interesting case history on a compressor rotor with a high coupling overhung moment. The authors most probably mis-diagnosed the Morton Effect as a high amplification critical speed in an overhung machine. It is interesting to see that they mitigated the problem by significantly increasing the overhung weight.

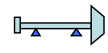
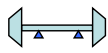
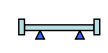
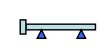
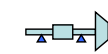
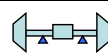
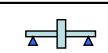
Another publication from L'vov and Gunter (2005) describes a case study of a 50MW generator rotor in a high-speed balancing facility with unexpected unstable rotordynamic behavior. This rotor has a long overhang at the turbine end and showed significant amplitude hysteresis between run up and coast down. It was recognized that the rotor was quite sensitive because of a 2<sup>nd</sup> mode critical speed. The rotordynamic analysis was focused on kinetic energy of the different rotor mode shapes. It was concluded that the amplitude hysteresis was disregarded as balancing facility specific and not present in normal operation, which was correct. Obviously, when the generator rotor was directly coupled in the field to the turbine the sensitivity of the overhung end was eliminated and the rotor ran satisfactorily. The wording chosen for the title of this paper is clearly pointing in the direction of the Morton Effect although this possible root cause was not mentioned in the paper.

Publications over the last 25 years confirm that the phenomenon was observed on different turbomachinery configurations. While the obvious candidates are overhung compressors and expanders, drive-through compressors and high horsepower equipment can also experience synchronous rotor instability. The author also observed the phenomenon on the high-speed pinion of a parallel shaft gearbox during a no-load American Petroleum Institute (API) string test. The overhung moment of this gear was formed by a heavy coupling hub including the half spacer weight that was connected with a flexible element.

## CASE STUDY

A typical case study is presented to show the characteristics of the phenomenon and how it can possibly be cured. This case study involves a 30,000 hp (22 MW) gas boost compressor for an offshore application. A discharge pressure of 2700 psi (186 bar) is reached at a maximum continuous speed (MCS) of 12,700 rpm. Five 15.75 inches (400 mm) diameter impellers were needed to boost the natural gas from the 950 psi (65.5 bar) suction pressure with a gas turbine drive. The high power input to the shaft required a large shaft end coupling and, accordingly, a greater overhang to accommodate the increased size. Figure 8 presents a cross-section of the compressor assembly. The greater overhung moment at the coupling end is evident from this picture.

Following the theoretical development of thermal rotor instability theory and its successful application in identifying susceptible rotors, the analytical method was added as part of the “standard” rotordynamic calculations. The latter included an undamped critical speed analysis, an unbalance response calculation, and a study of the sensitivity to aerodynamic and seal destabilizing forces. These studies are performed during the initial design stage of the compressor rotor-bearing system to determine its dynamic behavior and acceptability to the job specifications both internal and external.

The thermal rotor stability of the gas boost compressor was calculated using a procedure simplified in Figure 5 and explained in more detail in another publication (de Jongh and Van der Hoeven, 1998). A plot of the complex gain vector for the gas boost compressor is shown on Figure 9. In this format, the unstable region is shown as the crosshatched area. The coupling end of the compressor was predicted to go unstable near the MCS and reached a value of the real component of about 1.3 at trip speed.

At this point, the gas turbine supplier (the coupling purchaser) was informed that the coupling overhung weight was too high. Discussions with the coupling vendor did not result in sufficient reductions in weight. Lacking viable options, a decision was made to proceed with the coupling and rotor design in its original form. The decision was influenced by the thermal index of rotors currently operating in the field. Some were identified with real parts of the index slightly higher than for this compressor. While these compressors did not possess a configuration similar to the gas boost compressor under review and with the perceived lack of alternatives, it was felt they represented a sufficient database to proceed with the design. The gas boost compressor proceeded to the test floor to undergo an API mechanical running test. At maximum continuous rotor speed (MCS), proximity probe readings were below the API limit at both ends of the compressor. However, during the excursion to trip speed at 13,300 rpm, high vibration was noted on the coupling end of the rotor. Vibration levels remained low until trip speed was reached. Once there the rotor became unstable and vibration grew over a several minute time span. Figure 10 shows a Bode plot of the coupling end X-probe. Immediate identification of the problem as thermal rotor instability was made upon review of the vibration plot. The classical hysteresis loop in the synchronous vibration is evident in both the amplitude and phase angle. Unfortunately, the shop test verified the analytical prediction that the rotor was sensitive to this phenomenon at trip speed.

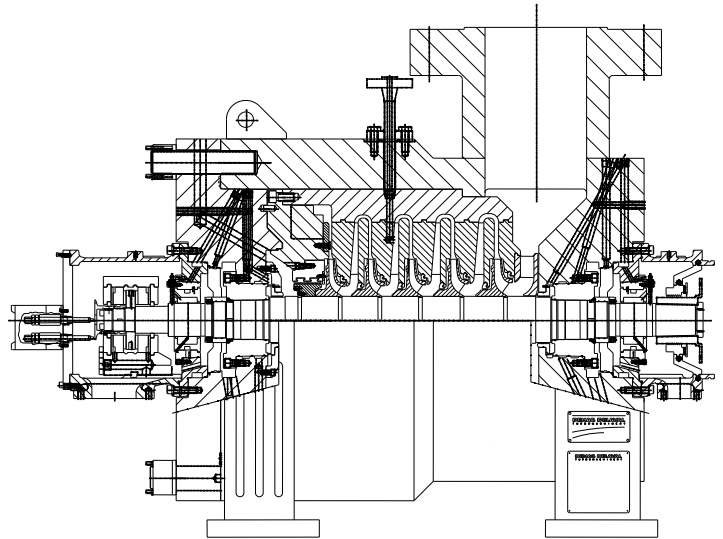

Figure 8. Cross-Section of 30,000 HP Gas Boost Compressor (Kocur and de Jongh, 2000)

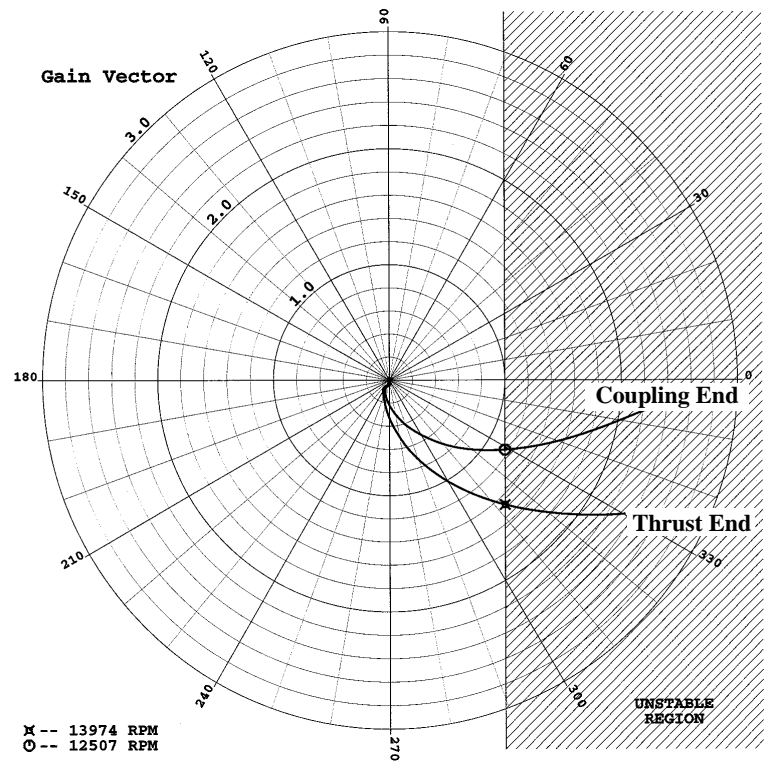

Figure 9. Complex Gain Vector for the Gas Boost Compressor (Kocur and de Jongh, 2000)

Methods to reduce the sensitivity of the compressor to thermal instability with minimal impact to the project were investigated. While the compressor manufacturer had successfully designed heat barrier sleeves for several rotors at this point, sleeves were not possible due to the high power input to the shaft. In order to transmit the power, a large coupling and shaft end were required. This shaft diameter at the coupling was limited by the size of the radial bearing. This proved to be the largest practical size of the radial bearing for this application keeping losses and heat production to a minimum. However, the lack of a diameter change between the radial bearing and coupling did not permit the installation of a sleeve that maintained the radial bearing size. Oversized bearing and new housings would be required that would severely impact the schedule of the project.

Bearing clearance changes have also been used by the compressor manufacturer to reduce the thermal instability of compressor rotors. In its current rotor-bearing configuration, the gas boost compressor had satisfactory safety margin for critical speed separation and dynamic stability of the first lateral mode. Modifications to the bearing clearance needed to improve the thermal rotor stability were found to erode these safety margins to unsatisfactory levels.

A significant factor in determining the thermal rotor stability of the gas boost rotor is the overhung mass of the coupling.

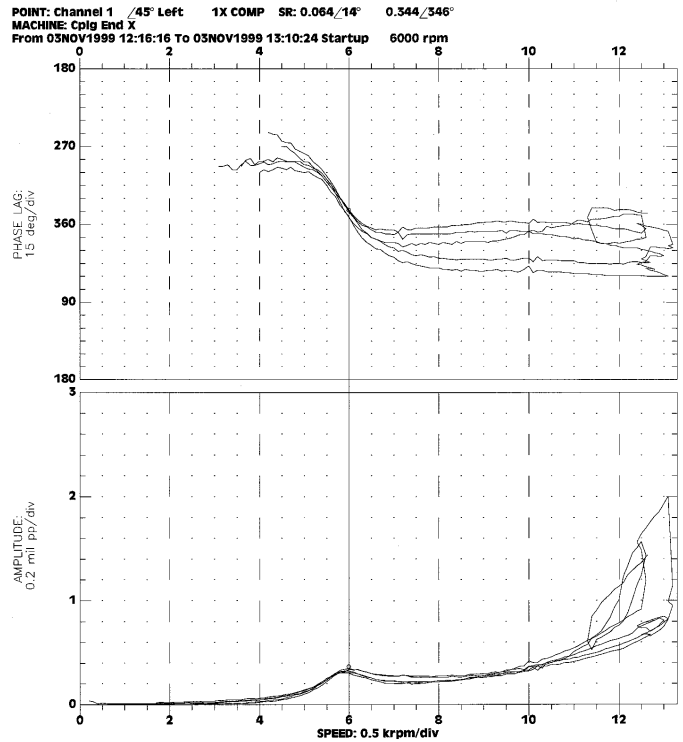

Figure 10. Synchronous Vibration on Test Stand (Coupling End) (Kocur and de Jongh, 2000)

With the failure of the mechanical test, more urgent discussions were held with the coupling manufacturer and an alternate supplier was sought. From these discussions, several new options were identified. The original coupling (noted as “Original” on Figure 11) had an overhung moment from the radial bearing centerline of 5415 kg-mm. Early on in the design process, the manufacturer proposed a modification of the original coupling (Mod A). This reduced the overhung moment to 4954 kg-mm or an 8.5 percent reduction. The manufacturer also proposed a reduced moment coupling (Mod C) that reduced the overhung moment by 29 percent. Finally, an alternate selection (Mod B) from a different vendor was obtained that reduced the overhung moment by 22 percent. An overhung moment reduction of 26 percent (Hypothetical) was required by the thermal analysis calculations to meet the internal design requirements. The thermal rotor instability for each rotor/coupling configuration was calculated at MCS and trip speed. Figure 11 presents the results of this study.

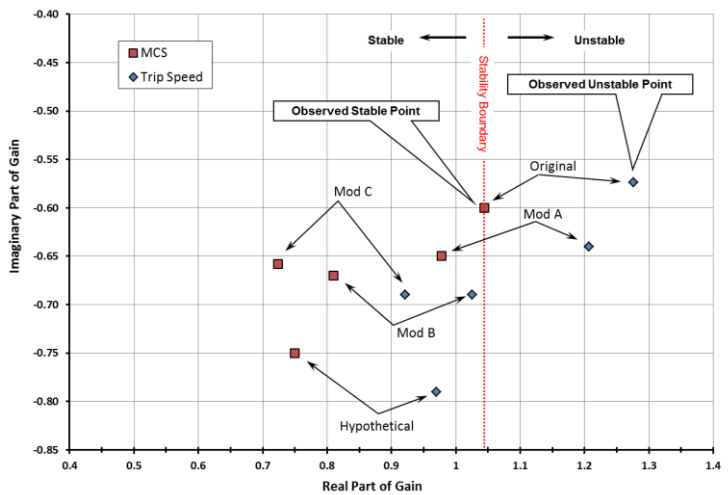

Figure 11. Predicted Thermal Gain of Various Coupling Configurations (Kocur and de Jongh, 2000)

Since the rotor behavior with the original coupling at MCS was found to be stable during the mechanical test, this was identified as the stability threshold. The study of the Mod A coupling did not predict both MCS and trip would be on the left (stable) side of the threshold. Of all the coupling configuration options, only the reduced moment and the coupling from the alternate vendor were predicted to be stable at both MCS and trip speed. However, due to the modifications required to the bearing housing and oil guard,



the reduced moment coupling was rejected as having too great an impact on the project schedule.

To minimize the impact of the lead-time necessary for delivery of a new coupling, a test coupling was modified to mimic the overhung mass. This permitted the testing to be carried out with minimal delays. The new coupling would be delivered in time for the string testing with the gas turbine. Figure 12 plots the vibration from minimum to trip speed for the coupling end X-probe. There is no sign of hysteresis or transient vibration. The synchronous levels are now completely stable through trip speed at levels far below the API limit.

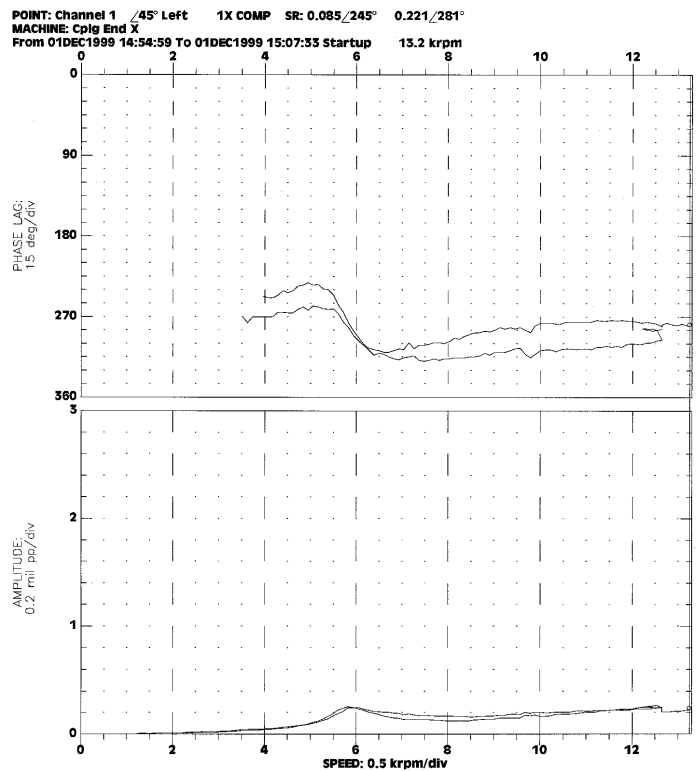

Figure 12. Synchronous Vibration with Reduced Coupling Overhung Moment (Kocur and de Jongh, 2000)

## PREDICTION OF SYNCHRONOUS ROTOR INSTABILITY

A number of researchers have developed computer models in order to be able to predict the phenomenon of synchronous rotor instability during the design phase of turbomachinery. These models can of course also be used for troubleshooting when synchronous instability is earmarked as the root cause of a rotor vibration problem. The early calculation tools to predict the Morton Effect were based on linear steady-state models for obtaining the onset speed of synchronous instability. These calculations were adequate for design engineers to predict onset of instability and for troubleshooting activities. Calculation models required coupling of different disciplines, such as rotordynamics, fluid dynamics and thermal analysis. If shaft journal temperature data was not obtained by experiments, journal differential temperatures had to be established by calculations using energy equations or CFD methods (Tucker and Keogh, 1996; Comiciaga and Keogh, 1999; Kirk et al., 2003; Schmied et al., 2008; Murphy and Lorenz, 2010; Grigor'ev et al., 2015).

Schmied (1987) based his model on the theories of Kellenberger (1979). This model allows investigation of rotor instability resulting from hot spots on general rotor systems. It allows the investigation of hot spots due to generator seal rings, brushes and bearings. The model incorporates a thermal equation between the thermal deflection of the shaft and the shaft displacement or velocity at the hot spot location.

Kirk (2000) employs a thermal bending model that involves solving the energy equation for the circumferential temperature distribution on the bearing journal. The temperature distribution is used to calculate the thermal overhung unbalance. A threshold unbalance has been defined and instability will occur if the thermal unbalance is greater than the threshold unbalance.

De Jongh and van der Hoeven (1998) have based their model on the theory of Morton (1994) and on experimental data from a bearing test rig. Nonuniform temperature profiles were measured on rotating shafts under different operating conditions and were related to the size of the bearing journal orbits. The program first calculates the distributed unbalance for unit thermal bending at the bearing journals respectively and then calculates the rotor response at the bearing locations. The experimental data are implemented to establish the differential temperatures across the shaft resulting in an output thermal bend. The ratio between the output and the input

bend is a complex gain vector and the modulus of this vector is used as criterion for stability. Murphy and Lorenz (2010) developed a simplified method to model shaft differential heating in any type of journal bearing and applied this model for Morton Effect analysis. Besides predicting onset of rotor instability with steady-state models, research was performed to better understand and explain what happens during unstable rotor behavior. For those investigations more advanced time dependent calculation models were required. Professor Allan Palazzolo at Texas A&M University initiated various research projects which resulted in the development of an advanced Morton Effect prediction algorithm. Suh and Palazzolo (2014) suggested a computational algorithm for the nonlinear transient analysis of the Morton Effect and Tong and Palazzolo (2017) successfully applied this model for a double overhung disk rotor. This algorithm appeared to be more accurate than the linear models, however with the impact of longer required computational time. Joachim Schmied, who successfully included a Morton Effect analysis into the software package MADYN 2000, was able to co-develop a new mathematical model that combined model accuracy with computational efficiency (Grigor'ev, et al., 2015). Further improvements have been scheduled for MADYN 2000 (Delta JS, 2016).

Childs and Saha (2012) took another interesting approach by performing synchronous rotordynamic response calculations including the Morton Effect. They analyzed rotor systems by iteratively construct equilibrium orbits, starting from mechanical unbalance and adding thermal unbalance by bent shafts due to journal differential temperatures. Since standard rotor response predictions without taking into account the thermal unbalance are basically in error to some extent (Morton,2008), this approach gives a possibility to more accurately predict rotor response.

#### *Experimental work*

In 2012 Bradley performed a fundamental study on the Morton Effect including experiments to measure bearing journal differential temperatures. For this purpose both a rigid rotor and a flexible rotor were designed and tested. Two types of bearings were applied being a bearing with a fixed offset half geometry and a tilting pad type bearing with a diameter of 50mm (2.0"). Bearing journal differential temperatures were established with calibrated thermistors and maximum differential temperatures of 1.5 – 1.7 °C were measured. These values appeared to be significantly lower than the values predicted using the model of Balbahadur (2001) for the same orbit sizes.

In order to verify the stability of an experimental rotor-bearing system Panara et al. (2015) applied the linear model from Murphy and Lorenz (2010) and also compared this analysis with an iterative FEM thermo-structural-dynamic analysis. The rotor was designed with a relatively large adjustable overhang end with three different configurations. The bearing journal at the overhang end was instrumented with thermocouples to measure journal differential temperatures and during an extensive test program it was possible to run the rotor unstable. The results of this investigation showed that the linear approach was adequate to predict the onset of instability efficiently, although some difficulties were observed for establishing phase lag between high spot and hot spot.

Tong and Palazzolo (2018) also performed experimental work to calibrate their transient Morton Effect analysis code. The test rig designed consists of a short shaft supported by two roller bearings and a hydrodynamic tilting pad bearing with a diameter of 3.15" (80mm) installed at mid span. The journal was intentionally machined to be eccentric with the roller bearings resulting in fixed circular orbit geometry independent of rotor speed (5.4 mils pk-pk). Experiments were focused on journal differential temperatures and phase lag between the high and hot spot locations. Based on the measurement results the earlier developed more simplified but fast linear steady-state model was updated and showed improved accuracy.

Various suppliers of turbomachinery developed their own internal codes to predict rotor instability due to the Morton Effect. Other software packages besides MADYN 2000 were developed by Texas A&M University (TRC Morton Effect Simulation) and Virginia Tech (VT-MAP 4.0). Antonini et al. (2016) implemented a thermohydrodynamic model into COMSOL Multiphysics® to predict the Morton Effect. Recently a few good review papers have been published on the Morton Effect and these include a more detailed overview of the various calculation models that have been developed until now (Gu, 2017; Tong, et al., 2017).

Calculation models need to be verified by actual rotor behavior. Unfortunately it is observed that only a very limited number of published case studies allow for proper verification. The author suggests investigating the possibility of a common research project in which an unstable rotor is designed, manufactured and being tested. Rotordynamic test data, including detailed rotor and bearing geometry, should be shared with the research partners in order to verify their individual models. The advantage of this approach may be that no critical research data such as measured differential temperatures have to be shared between competing companies but just standard rotordynamic geometry and vibration test data which should be adequate to further verify each company's individual codes.

#### **CORRECTIVE ACTIONS**

From the existing literature published thus far, it appears that the phenomenon is observed either during testing of new rotating machinery in the manufacturer's workshop, or in the field if changes are being made to existing machinery such as is the case for upgrades and rerates. Besides that, rotating machinery may exist in the field that is marginally stable. In such a case, the smallest change can result in an unstable rotor system.

If synchronous instability, due to nonuniform heating of the bearing journals, is considered as the root cause of a rotor vibration

problem, or is suspected during the design stage, the following corrective actions can be considered:

- Limit the “design” speed—By reducing the “design” speed, the vibration levels will usually decrease. This solution is not preferred as it limits the production capacity of the machine. For electric motor driven units, reducing the speed is not an option unless the motors have variable frequency control.
- Reduce overhang moments—Overhang moments can be reduced if lower density materials (titanium coupling spacers, aluminum impellers) are used. This pragmatic solution, in combination with a reduced moment coupling, has been successfully applied on a drive-through compressor rotor (de Jongh and Morton, 1994).
- Change bearing clearances—Reducing bearing clearances will result in higher viscous shear and larger differential temperatures across the bearing journal thus aggravating the thermal instability. Simultaneously, the bearing stiffness and damping will increase and result in a machine less sensitive to overhung unbalance. Synchronous instability is affected by both aspects and thus depends on which effect predominates.
- Reduce bearing length—Reducing the bearing length, for the same nonuniform temperature across the journal, will result in a smaller thermal bend. At the same time, the specific bearing loading and eccentricity ratio will also increase. (Refer also to “Increase specific bearing loading and eccentricity” below.) Schmied and Pozivil (2008) applied this method on a turboexpander with double overhung wheels in combination with reducing the oil viscosity.
- Change bearing type or geometry—The “problem” bearing can be replaced by a completely different type of bearing design less prone to differential heating of the bearing journal. This solution is also suggested by Marscher and McGinley (2004).
- Apply a heat barrier sleeve (patent protected)—The application of a heat barrier sleeve in order to solve a synchronous rotor instability problem has been described by De Jongh van der Hoeven (1998) and proved to be a very effective solution. Refer to Figure 13 for a typical heat barrier sleeve.

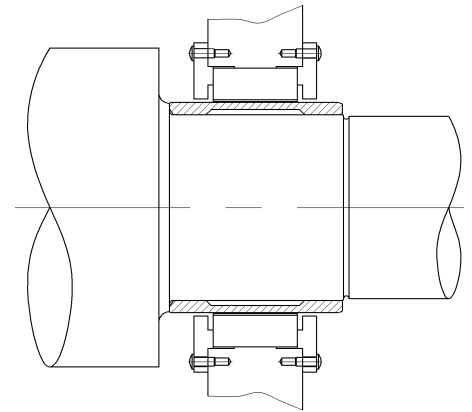

Figure 13. Typical Heat Barrier Sleeve (patent protected)

- Increase specific bearing loading and eccentricity—To solve a synchronous instability problem on an overhung compressor, Berot and Dourlens (1999) have increased the specific bearing loading by reducing the L/D ratio of the inboard bearing. At the same time the effective bearing journal length for the differential temperature across the journal was reduced. Balbahadur (2001) indicates that at higher eccentricity ratios the cooling effect in the bearing will be better, resulting in a lower differential temperature across the journal. Faulkner, et al. (1997), also successfully applied this method to solve a synchronous vibration instability problem on a radial inflow overhung turbine.
- Change shaft material—If steel with an austenitic structure is being used for the shaft material, a ferritic steel can be considered because of a lower linear expansion coefficient.
- Change lubrication oil viscosity —Increasing the bearing oil supply temperature will result in lower viscosity, lower viscous shear, and thus less differential heat input to the bearing journal. This method has successfully been applied by Marscher and McGinley (2004) on a double overhung air compressor and also by Schmied and Pozivil (2008) on a turboexpander. It should be noted that changing the oil supply temperature also alters bearing properties such as stiffness and damping.
- Increase inlet oil flow—If the bearing inlet oil flow is increased, cooling of the bearing journal improves and differential temperature across the journal will reduce. This method was successfully applied on the drive-end bearing of a 61 MW gas turbine by Morton in 1976 (Morton, 1976). The clearance on the top half of the bearing was increased, resulting in higher oil flow through the bearing that cooled the shaft.

Besides correcting Morton Effect problems, implementing one or more of the above indicated corrective actions may improve machines with a history of marginal synchronous vibration behavior.

## DISCUSSION

Design engineers of new turbomachinery usually have more degrees of freedom to prevent synchronous rotor instability. This will certainly be the case if design engineers are familiar with the Morton Effect and know which measures can be taken. Over the years it has become good engineering practice in turbomachinery design to keep overhung moments as small as possible. It is the opinion of the author that the phenomenon described in this paper has contributed to this practice since, in the past, many vibration problems could empirically be solved by reducing rotor overhung moments.

For existing turbomachinery showing synchronous rotor instability during mechanical testing or during operation in the field, the possibilities for significant design changes will usually be more limited. As with many vibration problems, this emphasizes the importance of understanding and analyzing the tendency of turbomachinery in the design stage.

The phenomenon described in this paper is not of interest to new turbomachinery only, but also important for the rerate compressor or expander applications, especially those with overhung wheels. Rerates are normally performed to increase the existing production capacity rate and efficiency. For the machine, this can result in larger overhung wheels and heavier couplings due to the increased power requirements, making the design more susceptible to the Morton Effect.

Faulkner, et al. (1997), describe a synchronous rotor instability problem on an upgraded turbocharger using the original shaft and compressor wheel but increased the turbine wheel mass with about 20 percent. This change resulted in unstable rotor.

Kirk, et al. (2003), describe that a compressor rerate was unstable at the test stand. The synchronous instability of this pipeline compressor with a single overhung impeller could be eliminated by significantly reducing the impeller-end bearing width.

Marsher and McGinley (2004) describe a case study in which a change in the lubrication oil temperature only resulted in unstable synchronous rotor vibrations.

Obviously, rotors that are stable however run at rotor speeds close to the onset of synchronous instability are being influenced by shaft journal differential heating. These rotors are very sensitive to overhung unbalances and may have a history of vibration problems. Peters and de Jongh (2010) describe a case study for a rotor with a single overhung impeller that was very sensitive to unbalance and from calculations appeared to be very close to the onset of instability. The vibration behavior could be significantly improved by reducing the impeller weight by 11%.

At Texas A&M University professor Alan Palazzolo investigated the Morton Effect not only for fluid-film oil bearings but also for tilting pad gas bearings and found that journal differential temperatures do also exist for gas bearings and can drive rotor systems unstable (Tong and Palazzolo, 2018).

### *API Design Standard*

For the design of new turbomachinery the API design standard gives requirements and guidelines. The section “DYNAMICS” covers rotordynamics for torsional analysis, lateral analysis, and different levels of subsynchronous stability analysis (for example: API 617 Standard, 2002). In various publications it is indicated that the API requirements for the turbomachinery design were met (Berot and Dourlens, 1999; de Jongh and Morton, 1994; de Jongh and van der Hoeven, 1998; Kocur, 2000; Schmied and Pozivil, 2008). However, the machines described in these case studies could not be operated at their design speed due to synchronous instability. The API 684, which is basically a tutorial on rotordynamics, included a small paragraph 3.5.2.5 to indicate that the Morton Effect is a potential cause of vibrations (API 684 Standard, 2005). However, since the Morton Effect is a basic rotordynamic phenomenon that can occur on all rotors supported by fluid-film journal bearings, the author suggests that consideration should be given to definition of simple but effective design rules being included into the API design standards. Unfortunately until now that has not been the case.

## CONCLUSIONS

This technical paper has provided an elementary overview of the Morton Effect, how it can be recognized in turbomachinery, and which corrective actions can be considered when synchronous vibration problems do occur. Technical literature on this subject has been summarized and various case studies have been used to explain the corrective actions. In order to reduce the occurrence of synchronous rotor instability in the future, it has been suggested that API design specifications include simple but effective design rules. Various calculation codes are available to more or less predict and describe the Morton Effect. Unfortunately only limited published case studies allow for proper verification of these codes. The author suggests investigating the possibility of a common research project in which an unstable rotor is designed, manufactured and being tested. Rotordynamic test data, including detailed rotor and bearing geometry, should be shared with the research partners in order to verify their individual models. The advantage of this approach may be that no critical research data such as measured or calculated differential temperatures have to be shared between competing companies, but just standard rotordynamic geometry and vibration test results which should be adequate to further verify each company's individual codes.

## NOMENCLATURE

$G$	= Gain vector
$I$	= Influence coefficient
$M_c$	= Concentrated overhung mass
$R$	= Radius
$T$	= Thermal gain
$U$	= Unbalance
$h$	= Distance between journal and bearing wall
$l$	= Overhang length
$t$	= Time
$v$	= Velocity
$\beta$	= Phase lag between high spot and hot spot
$\varepsilon$	= Orbit vector
$\phi$	= Phase angle between rotor unbalance and response
$\theta$	= Change in shaft slope at bearing journal
$\Omega$	= Rotational speed

## Subscripts

$i$	= Input
$o$	= Output
$O$	= Overhang position
$B$	= Bearing position

## APPENDIX A

### EXPERIMENTAL VERIFICATION OF BEARING JOURNAL DIFFERENTIAL HEATING

This Appendix describes an experimental verification of the theory that journals of fluid-film bearings do not have a uniform temperature distribution around the journal circumference, but that a nonuniform temperature distribution exists under specific conditions. The experiment was executed in 1992 for the rotordynamic research and development (R&D) project already mentioned (de Jongh and Morton, 1994). A simple test rotor, as shown in Figure A-1 was manufactured. The rotor was supported by two 4-inch tilting-pad journal bearings. In the nondrive-end (NDE) journal, four calibrated temperature sensors were installed at 0.04 inch (1.0 mm) below the journal surface and spaced 90 degrees apart. Since, according to the theory, the temperature distribution around the journal is sinusoidal, at least four temperature sensors were required to establish the direction and magnitude of any differential temperature across the journal. Details of the instrumentation used to record the temperatures may be found in the reference previously mentioned. The rotor was driven by a variable speed electric motor in the manufacturer's high-speed balancing facility. To transfer the electrical signals from the rotating shaft, a special transmitter (not requiring a slip-ring) was applied. A photograph of the rotor including the used instrumentation is given in Figure A-2. The shaft was accurately balanced according to ISO 1940 / G=1.0.

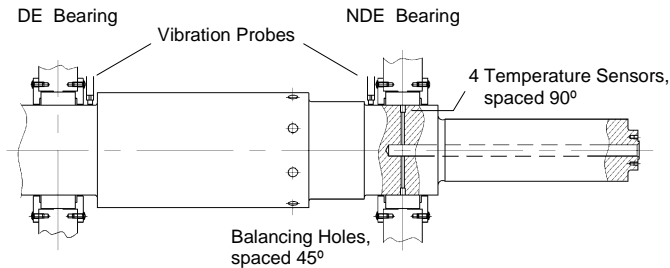

Figure A-1. Test Rotor with Four Temperature Sensors at the NDE Bearing.



Figure A-2. Test Rotor with Measuring Equipment.

During the run up of the shaft, the temperatures increased and when speed was kept constant at 12,500 rpm, they stabilized. Figure A-3 shows a cross section of the shaft at the bearing centerline with the four temperature sensors. The measured temperatures for the first run up, which are nearly equal, are given in Figure A-3(a). The orbit size at the NDE bearing was obtained with two displacement probes, spaced 90 degrees, and after subtraction of the slow roll vector, only around 2 microns (0.08 mils) peak-to-peak was measured at this speed.

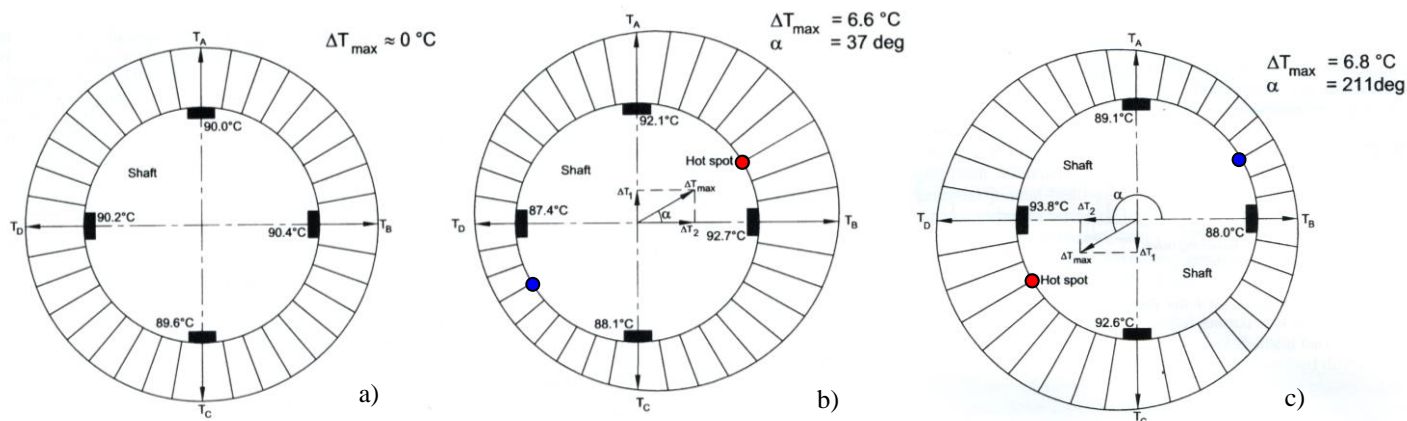

Figure A-3. Cross-Section of NDE Bearing Journal, with Sinusoidal Temperature Distribution.

The objective of the experiment was to generate a shaft orbit in the NDE bearing and measure the temperature distribution around the bearing journal. To generate a distinct shaft orbit in the bearing, an unbalance weight was applied on the shaft at a defined location at 0 degrees. Figure A-3(b) shows the four measured temperatures caused by this shaft orbit. After removing the weight, the temperature values shown in Figure A-3(a) were reproduced within 0.54°F (0.3°C). Figure A-3(c) shows the measured temperatures of the next run up where the unbalance was applied at the same axial location on the shaft, but now rotated over 180 degrees. As can be seen the direction of the differential temperature vector was also rotated over around 180 degrees.

## REFERENCES

- Antonini, M., Fausti, D., Mor, M., 2016, "Implementation of a Thermo-Hydrodynamic Model to Predict 'Morton Effect' ", COMSOL® Conference, Munich, Germany.
- API 617 Standard, 2002, "Axial and Centrifugal Compressors and Expander-Compressors for Petroleum, Chemical and Gas Industry Services," Seventh Edition, American Petroleum Institute, Washington, DC.
- API 684 Standard, 2005, "API Standard Paragraphs Rotordynamic Tutorial: Lateral Critical Speeds, Unbalance response, Stability, Train Torsionals, and Rotor Balancing," Second Edition, American Petroleum Institute, Washington, DC.
- Balbahadur, A. C., 2001, "A Thermoelastohydrodynamic Model of the Morton Effect Operating in Overhung Rotors Supported by Plain or Tilting Pad Journal Bearings," Ph.D. Thesis, Faculty of the Virginia Polytechnic Institute and State University, Blacksburg, Virginia.
- Berot, F. and Dourlens, H., 1999, "On Instability of Overhung Centrifugal Compressors," ASME Paper No. 99-GT-202.
- Bradley, P. J., 2012, "Fundamental Study into the Governing Conditions of Rotor Thermal Bows in Hydrodynamic Bearings," Ph.D. Thesis, Cranfield University, Cranfield, UK.
- Carrick, H. B., 1999, "Integrally Geared Compressors and Expanders in the Process Industry," IMechE Seventh European Congress on Fluid Machinery for the Oil, Petrochemical, and Related Industries, The Hague, The Netherlands.
- Childs, D. and Saha, R., 2012, "A New, Iterative, Synchronous-Response Algorithm for Analyzing the Morton Effect," ASME J. Eng. Gas Turbines Power, 134(7), p. 072501.
- Childs, D., 2015, "The Remarkable Turbomachinery-Rotordynamics Developments during the Last Quarter of the 20th Century," SAE Technical Paper 2015-01-2487.
- Corcoran, J., Rea, H., Cornejo, G. and Leonhard, M., 1997, "Discovering, the Hard Way, How a High Performance Coupling Influenced the Critical Speeds and Bearing Loading of an Overhung Radial Compressor - A Case History," 26th Turbomachinery Symposium, Houston, TX, Sept., pp. 67-78.

- Delta JS, 2016, "Hot Spot Stability Analysis available in MADYN 2000 Version 4.2," Available at: [http://www.delta-js.ch/file/344/MADYN\\_2000\\_Release\\_42\\_rev1.pdf](http://www.delta-js.ch/file/344/MADYN_2000_Release_42_rev1.pdf) (accessed May 31, 2018).
- Dimarogonas, A. D., 1973, "Newkirk Effect: Thermally Induced Dynamic Instability of High-Speed Rotors," ASME Paper No. 73-GT-26.
- Faulkner, H. B., Strong, W. F. and Kirk, R. G., 1997a, "Thermally Induced Synchronous Instability of a Radial Inflow Overhung Turbine PART I," *Proceedings of ASME Design Engineering Technical Conference*, Sacramento, California.
- Faulkner, H. B., Strong, W. F. and Kirk, R. G., 1997b, "Thermally Induced Synchronous Instability of a Radial Inflow Overhung Turbine, PART II," *Proceedings of ASME Design Engineering Technical Conference*, Sacramento, California.
- Gomiciaga, R. and Keogh, P., 1999, "Orbit Induced Journal Temperature Variation in Hydrodynamic Bearings," ASME J. Tribol., 121(1), pp. 77–84.
- Grigor'ev, B. S., Fedorov, A. E. and Schmied, J., 2015, "New Mathematical Model for the Morton Effect Based on the THD Analysis," Ninth IFToMM International Conference on Rotor Dynamics, Milan, Italy, Sept. 22–25, pp. 2243–2253.
- Gu, L., 2017, "A Review of Morton Effect: from Theory to Industrial Practice," *Tribology Transactions*, 61:2, 381-391.
- Gu, L., 2018, "A Simplified and Efficient Analysis of Morton Effect," *Proceedings of ASME Turbo Expo*, GT2018-75948, June 11-15, Oslo, Norway.
- Guo, Z. and Kirk, G., 2011, "Morton Effect Induced Synchronous Instability in Mid-Span Rotor–Bearing Systems—Part I: Mechanism Study," ASME J. Vib. Acoust., 133(6), p. 061004.
- Guo, Z. and Kirk, G., 2011, "Morton Effect Induced Synchronous Instability in Mid-Span Rotor–Bearing Systems—Part II: Models and Simulations," ASME J. Vib. Acoust., 133(6), p. 061006.
- Hesseborn, B., 1978, "Measurements of Temperature Unsymmetries in Bearing Journal Due to Vibration," Internal Report ABB Stal.
- de Jongh, F. M. and Morton, P. G., 1994, "The Synchronous Instability of a Compressor Rotor Due to Bearing Journal Differential Heating," ASME Paper No. 94-GT-35. Also published in ASME Transactions, *Journal of Engineering for Gas Turbines and Power*, 118, October 1996, pp. 816-824.
- de Jongh, F. M. and van der Hoeven, P., 1998, "Application of a Heat Barrier Sleeve to Prevent Synchronous Rotor Instability," *Proceedings of the Twenty-Seventh Turbomachinery Symposium*, Turbomachinery Laboratory, Texas A&M University, College Station, Texas, pp. 17-26.
- de Jongh, F. M., 2008, "The Synchronous Rotor Instability Phenomenon - Morton Effect," 37th Turbomachinery Symposium, Houston, TX, Sept. 8–11, pp. 159–167.
- Kellenberger, W., 1979, "Spiral Vibrations Due to Seal Rings in Turbogenerators. Thermally Induced Interaction Between Rotor and Stator," ASME Paper No. 79-DET-61. Also published in ASME Transactions, *Journal of Mechanical Design*, 102, January 1980, pp. 177-184.
- Keogh, P. S. and Morton, P. G., 1993, "Journal Bearing Differential Heating Evaluation with Influence on Rotor Dynamic Behaviour," *Proceedings of the Royal Society*, London, England, A441, pp. 527-548.
- Keogh, P. S. and Morton, P. G., 1994, "The Dynamic Nature of Rotor Thermal Bending Due to Unsteady Lubricant Shearing Within a Bearing," *Proceedings of the Royal Society*, London, England, A445, pp. 273-290.
- Keogh, P. S., 2017, "Discussion of 'A Review of the Rotordynamic Thermally Induced Synchronous Instability (Morton) Effect,'" ASME Appl. Mech. Rev., 69(6), p. 060801.
- Kirk, R. G., 2000, "Design Guidelines for Improved Rotating Machinery Stability," Seventh International Conference on Vibrations in Rotating Machinery, IMechE C576/115.
- Kirk, R. G. and Balbahadur, A. C., 2000, "Thermal Distortion Synchronous Rotor Instability," Seventh International Conference on Vibrations in Rotating Machinery, IMechE C576/041.
- Kirk, R. G., Guo, Z. and Balbahadur, A. C., 2003, "Synchronous Thermal Instability Prediction for Overhung Rotors," *Proceedings of the Thirty-Second Turbomachinery Symposium*, Turbomachinery Laboratory, Texas A&M University, College Station, Texas, pp. 121-135.
- Kirk, R. G. and Guo, Z., 2005, "Morton Effect Analysis – Theory, Program and Case Study," ISCORMA-3, Cleveland, Ohio, 19-23 September.

- Kirk, G. and Guo, Z., 2013, "Design Tool for Prediction of Thermal Synchronous Instability," ASME Paper No. DETC2013-12966.
- Kocur, J. A. and de Jongh, F. M., 2000, "Thermal Rotor Instability in Gas Compressors," AVPG 14th International Gas Convention, Caracas, Venezuela.
- Larsson, B., 1999a, "Journal Asymmetric Heating - Part I: Nonstationary Bow," ASME Transactions, *Journal of Tribology*, 121, pp. 157-163.
- Larsson, B., 1999b, "Journal Asymmetric Heating - Part II: Alteration of Rotor Dynamic Properties," ASME Transactions, *Journal of Tribology*, 121, pp. 164-168.
- Lee, J. and Palazzolo, A., 2012, "Morton Effect Cyclic Vibration Amplitude Determination for Tilt Pad Bearing Supported Machinery," ASME J. Tribol., 135(1), p. 011701.
- Lorenz, J., 2009, "Implementation of Fluid-Film Bearing Shaft Differential Heating Calculations Using Commercial CFD Software," M.S. thesis, University of Illinois at Urbana-Champaign, Champaign, IL.
- Lorenz, J. and Murphy, B., 2011, "Case Study of Morton Effect Shaft Differential Heating in a Variable-Speed Rotating Electric Machine," ASME Paper No. GT2011-45228.
- L'vov, M. M. and Gunter, E. J., 2005, "Application of Rotor Dynamic Analysis for Evaluation of Synchronous Speed Instability and Amplitude Hysteresis at 2<sup>nd</sup> Mode for a Generator Rotor in a High-Speed Balancing Facility," ISCORMA-3, Cleveland, Ohio, 19-23 September.
- Marin, M., 2012, "Rotor Dynamics of Overhung Rotors: Hysteretic Dynamic Behavior," ASME Paper No. GT2012-68285.
- Marscher, W.D. and McGinley, J. J., 2004, "Experimental Investigation of Cyclic Vibration Morton Effect in the Bearings of a Double Overhung Compressor," 58th Meeting of the Society for Machinery Failure Prevention Technology, Virginia Beach, Virginia.
- Morton, P. G., 1975, "Some Aspects of Thermal Instability in Generators," G.E.C. Internal Report No. S/W40 u 183.
- Morton, P. G., 1976, "An Interim Note on One Aspect of the Running Characteristics of a Gas Turbine," G.E.C. Internal Report No. S/W40 u 226.
- Morton, P. G., 1994, "Recent Advances in the Study of Oil Lubricated Journal Bearings," *Proceedings of the Fourth International Conference on Rotor Dynamics*, IFFToMM, Chicago, Illinois, pp. 299-305.
- Morton, P. G., 2008, "Unstable Shaft Vibrations Arising from Thermal Effects Due to Oil Shearing Between Stationary and Rotating Elements," IMechE Ninth International Conference on Vibrations in Rotating Machinery, Exeter, England, September 2008.
- Murphy, B. and Lorenz, J., 2010, "Simplified Morton Effect Analysis for Synchronous Spiral Instability," ASME J. Vib. Acoust., 132(5), p. 051008.
- Newkirk, B. L., 1926, "Shaft Rubbing," *Mechanical Engineering*, 48, pp. 830-832.
- Phuttipongsit, A., 2007, "The Morton Effect and Light Rubs in Rotating Machinery," *ORBIT Magazine*, 27, (1), pp. 44-51.
- Panara, D., Panconi, S. and Griffini, D., 2015, "Numerical Prediction and Experimental Validation of Rotor Thermal Instability," 44th Turbomachinery Symposium, Houston, TX, Sept. 14-17.
- Peters, M. and de Jongh, F.M., 2010, "Synchronous Rotor Vibrations due to Bearing Journal Differential Heating," IMechE Eleventh European Fluid Machinery Congress, 12-15 September, Edinburgh, Scotland.
- Schmied, J., 1987, "Spiral Vibrations of Rotors," *Rotating Machinery Dynamics*, 2, Proceedings of ASME Design Technology Conference, Boston, Massachusetts.
- Schmied, J., Pozivil, J. and Walch, J., 2008, "Hot Spots in Turbo-Expander Bearings: Case History, Stability Analysis, Measurements and Operational Experience," ASME Turbo Expo 2008, Berlin, Germany.
- Suh, J., 2014, "High Fidelity Simulation of Rotordynamic Morton Effect by Nonlinear Transient Approach," partial fulfillment of requirements for Ph.D. thesis, TAMU, College Station, TX.
- Suh, J., 2014, "Nonlinear Transient Rotor-Bearing Dynamic Analysis Considering Shaft Thermal Bow Induced Instability Problem," Ph.D. thesis, TAMU, College Station, TX.
- Suh, J. and Palazzolo, A., 2014, "Three-Dimensional Thermohydrodynamic Morton Effect Simulation - Part I: Theoretical Model," ASME J. Tribol., 136(3), p. 031706.



- Suh, J. and Palazzolo, A., 2014, "Three-Dimensional Thermohydrodynamic Morton Effect Simulation - Part II: Parametric Studies," ASME J. Tribol., 136(3), p. 031707
- Tong, X., Palazzolo, A. and Suh, J., 2016, "Rotordynamic Morton Effect Simulation with Transient, Thermal Shaft Bow," ASME J. Tribol., 138(3), p. 031705.
- Tong, X. and Palazzolo, A., 2016, "Double Overhung Disk and Parameter Effect on Rotordynamic Synchronous Instability—Morton Effect - Part I: Theory and Modeling Approach," ASME J. Tribol., 139(1), p. 011705.
- Tong, X. and Palazzolo, A., 2016, "Double Overhung Disk and Parameter Effect on Rotordynamic Synchronous Instability—Morton Effect - Part II: Occurrence and Prevention," ASME J. Tribol., 139(1), p. 011706.
- Tong, X. and Palazzolo, A., 2016, "The Influence of Hydrodynamic Bearing Configuration on Morton Effect," ASME Paper No. GT2016-56654.
- Tong, X. Palazzolo, A., and Suh, J., 2017, "A Review of the Rotordynamic Thermally Induced Synchronous Instability (Morton) Effect," ASME Appl. Mech. Rev., 69(6), p. 060801.
- Tong, X., Palazzolo, A. and Suh, J., 2017, "Closure to "Discussion of 'A Review of the Rotordynamic Thermally Induced Synchronous Instability (Morton) Effect,'" ASME Appl. Mech. Rev., 69(6), p. 060801.
- Tong, X. and Palazzolo, A., 2018, "Measurement and Prediction of the Journal Circumferential Temperature Distribution for the Rotordynamic Morton Effect," ASME J. Tribol., 140(3), p. 031702.
- Tong, X. and Palazzolo, A., 2018, "Tilting Pad Gas Bearing Induced Thermal Bow – Rotor Instability (Morton Effect)," Tribology International, 121, pp. 269-279.
- Tucker, P. G. and Keogh, P. S., 1996, "On the Dynamic Thermal State in a Hydrodynamic Bearing with a Whirling Journal using CFD Techniques," ASME Transactions, *Journal of Tribology*, 118, pp. 356-363.

## BIBLIOGRAPHY

- API 613 Standard, 2003, "Special-Purpose Gear Units for Petroleum, Chemical and Gas Industry Services," Fifth Edition, American Petroleum Institute, Washington, DC.
- Balbahadur, A. C. and Kirk, R. G., 2002, "Part I - Theoretical Model for a Synchronous Thermal Instability Operating in Overhung Rotors," *Proceedings of Sixth International Conference on Rotor Dynamics, IFToMM, Sydney, Australia*.
- Balbahadur, A. C. and Kirk, R., 2004, "Part II - Case Studies for a Synchronous Thermal Instability Operating in Overhung Rotors," *Int. J. Rotating Mach.*, 10(6), pp. 477-487.
- Balbahadur, A. C. and Kirk, R. G., 2002, "Part II—Case Studies for a Synchronous Thermal Instability Operating in Overhung Rotors," *Proceedings of Sixth International Conference on Rotor Dynamics, IFToMM, Sydney, Australia*.
- Childs, D.W., 2013, "Turbomachinery Rotordynamics with Case Studies," Wellborn, Texas 77845, Minter Spring Publishing, pp 113-122.
- Eckert, L. and Schmied, J., 2007, "Spiral Vibrations of a Turbogenerator Set: Case History, Stability Analysis, Measurements and Operational Experience," ASME Turbo Expo: Land, Sea and Air, Montreal, Quebec, Canada, ASME Paper No. GT2007-27314. Also published in ASME *Journal of Engineering for Gas Turbines and Power*, 130, 012509, 2008.
- Eckert, L., Schmied, J., and Ziegler, A., 2006, "Case History and Analysis of the Spiral Vibration of a Large Turbogenerator Using Three Different Heat Input Models," *Proceedings of Seventh International Conference on Rotor Dynamics, IFToMM, Vienna, Austria*.
- Eldridge, T. M., Olsen, A. and Carney, M., 2009, "Morton-Newkirk Effect in Overhung Rotor Supported in Rolling Element Bearings," ASME Paper No. GT2009-60243.
- den Hartog, J. P., 1956, *Mechanical Vibrations*, New York, New York: McGraw-Hill Book Company.
- Larsson, B., 1998, "Gas Turbine Rotor Exposed to the Newkirk Effect," IFToMM, Fifth International Conference on Rotor Dynamics, Darmstadt, Germany, pp. 286-297.
- Marscher, W. D. and Illis, B., 2007, "Journal Bearing "Morton Effect" Cause of Cyclic Vibration in Compressors," *Tribology Transactions*, Volume 50, Issue 1, pp. 104-113.

Marscher, W. D. and McGinley, J. J., May 2006, "Vibration Troubleshooting of an Air Compressor," *Journal of Sound and Vibration*, Based on Marscher and McGinley, 2004.

Takahashi, N. and Kaneko, S., 2013, "Thermal Instability in a Magnetically Levitated Doubly Overhung Rotor," *J. Sound Vib.*, 332(5), pp. 1188–1203.

## **ACKNOWLEDGEMENTS**

The author wishes to thank the management of EthosEnergy for their permission to publish this paper. Thanks also to John Kocur, who supported the author again with useful suggestions. Special thanks to all authors and coauthors of the referenced papers, who made it possible to prepare this updated overview on the Morton Effect and last but not least, thanks to Paul Morton for all interesting discussions.